

Koyo

KC01 Series Counter

KC01 — 4/6

Thank you for purchasing KC01 series counters. Please read this Operation Manual carefully before applying this counter product.

Koyo Electronics(Wuxi)Co.,LTD

Addr: No.118 Lixi Road Wuxi, Jiangsu, P.R.China
Pc:214072 Tel: (0510)85167888
Fax: (0510)85161393

KEW-M8371D-E

Front Panel Layout and Description

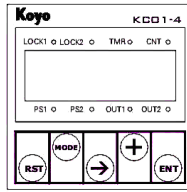

- LOCK1 Set key (MODE) lock display
- LOCK2 Reset key (RST) lock display
- TMR Timer status
- CNT Count status
- PS1 Preset 1 display
- PS2 Preset 2 display
- OUT1 Output 1 display
- OUT2 Output 2 display
- RST Reset key
- MODE Mode/Set key
- Right arrow key
- + Select set value or sub menu
- ENT Confirm key

Item	Specifications
Source voltage	AC: 85~265V/ DC: 20~35V(two inputs points) DC: 20~35V (DC type no AC inputs)
Power consumption	AC: 5VA DC: 2AV
Sensor power (Ac output only)	12V±10%, 24V±10% simultaneous output ripple ≤ 10% P-P
Output current	12V/60mA, 24V/60mA (note: Two CH sum-current ≤ 60mA)
Memory backup	EPR0M (up to 100,000 writes) store periods for 10 years
Ambient temperature	-10~50°C
Storage temperature	-25~70°C (with no freezing)
Ambient humidity	35~85% (with no dewing)
Insulation resistance	DC500V 100MΩ (between AC power terminals~every lower voltage terminals Between every lower voltage terminals~relay output terminals, between AC power terminal~relay output terminal)
Protection	IP64 for the keypad on the front panel against dust and splash.

Output mode diagrams

Timer mode

When DIP switch2 sets ON position (positive logic), the diagrams is shown below. If you select the negative logic, please reverse all levels and sets the reset signal to lower level. "SET" means preset value, "START" means the timer start signal (INA), "OUT" means OUT1 output.

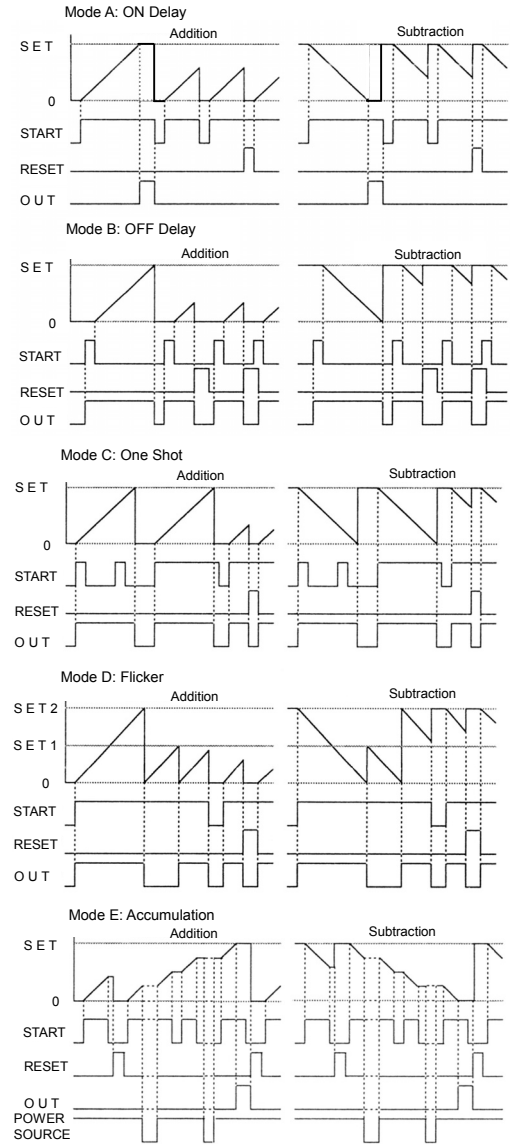

Counter mode

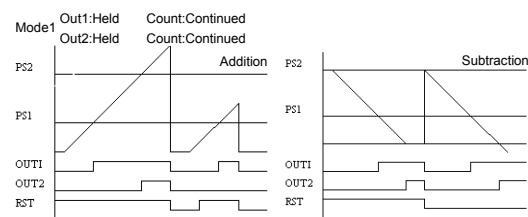

Performance Specification

Function	Addition or subtraction, Addition and subtraction, Timer
Number of digits	4 or 6 digits(LED)
LED Character Height	4digits: 10mm 6digits:8mm
Setting range	4digits: -999~9999 6digits: -99999~999999
Counting range	4digits: -999~9999 6digits: -99999~999999
Memory backup at power failure	Yes/No(selectable)
Max.frequency	30/1K/2K/5KHZ
Key protection	Key protection cover, Reset Lock (lock1), Set Lock (lock2)
Power reset	Power shutdown duration: ≥2s; Reset duration: ≤1s (until restart)
Input logic	positive/negative (NPN/PNP, voltage/no voltage)
Preset	Dual preset/Single preset
Input	INA, INB, INH, RST
	Input resistance: Positive:3.3KΩ Negative:3.3KΩ
	Input voltage: "L" 0~3V, "H" 7~30V Peak voltage: -15V~65V (PP value: -300V~300V)
Input mode	Addition and/or subtraction, Two-phase, Disable input, External reset input
Decimal point display	Any location
prescaling	4digits: 0~99.99 6digits: 0~99.999
Count disable input	Responded ≤ 0.2ms (input at 5kHz)
External reset	Minimum pulse width:0.6ms
Auto reset	Responded ≤ 0.2ms
Manual reset	responded ≤ 0.1ms
Output mode	One shot(momentary output), Hold, compare
Output	Two segment individually(NPN open collector, relay output simultaneously for every segment)
Output specification	Relay: 250V 2A, NPN:100mA/35V(but 60mA with relay output simultaneously, Two voltage types:TTL, Vcc (Vcc:extra ≤35V))
One shot output duration	10~999ms
Timer range	4 digits: 999.9s, 9999s, 9min59.9s, 99min59s, 9999min, 9h59min5s ^{*1} , 99h59s, 9999h 6digits: 9999.90s ^{*2} , 99999.9s, 999999s, 99min59.90s ^{*2} , 999min59.9s, 9999min5s ^{*1} , 99999min, 99h59min59s, 9999h59s

Note1: The last seconds is 10 seconds for the unit of time. The actual number of seconds to be multiplied by 10.

Note2: The last digit displays fixed at 0, the actual significant digit is only 5 digits.

Change a preset value

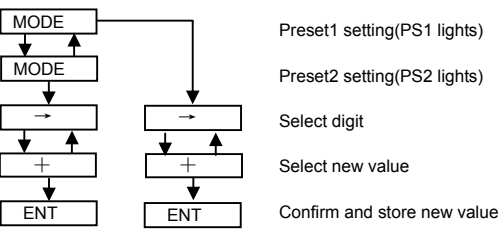

- Note:
- The PS1 and PS2 setting are both disable when LOCK1 lamp lights.
 - The RST key is disable to reset displaying values when the RST key is locked(LOCK2 lamp lights).

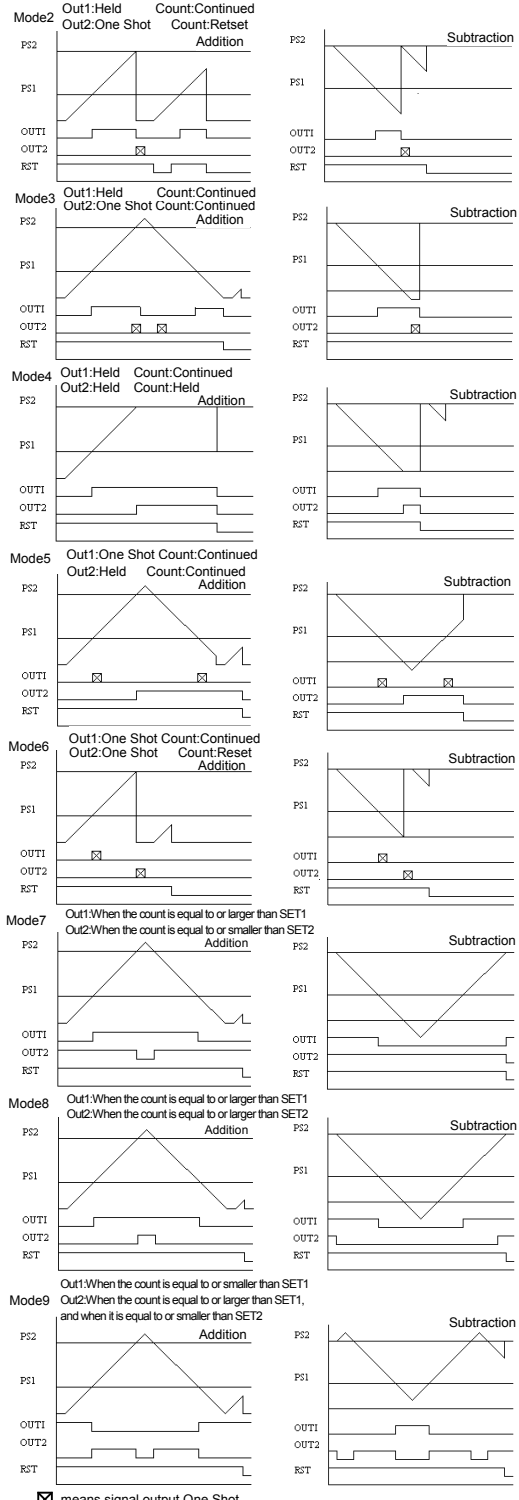

☒ means signal output One Shot

Input timing

Two-phase mode/positive logic:

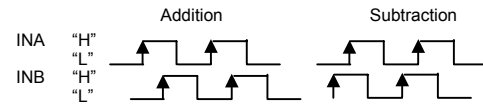

Two-phase mode/negative logic:

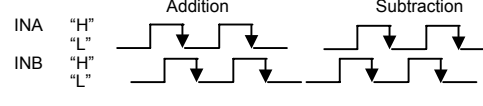

Addition or Subtraction/positive logic:

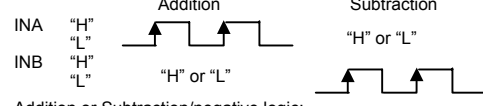

Addition or Subtraction/negative logic:

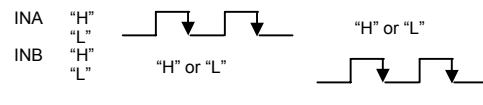

Note: The diagram above shows the assumption that the rotary encoder is rotating anti-clockwise, if the encoder is rotating clockwise, the addition diagram is adverse to the subtraction diagram.

Menu Setup

- The Timer/Counter function mode is selected by DIP switches.

(note:When DIP switches are re-configured, you must turn power off and the configure will become effective after turn power on again.)

- Press the MODE key and the + key at the same time for at least 0.5 second to enter the menu setup, or leave the system in the setup mode. In the setup mode, the MODE key can change the menu. The + key can select a new value or change submenu. The - key can shift one digit to the right. The ENT key is confirm key to store the configuration.

- The dual preset output has nine mode. The single preset output has six mode.

Timer operation

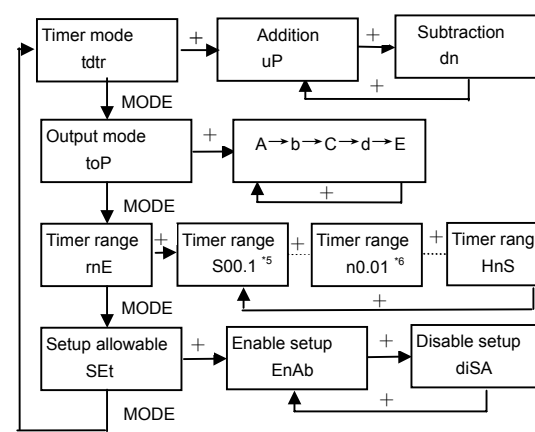

Wiring Diagrams

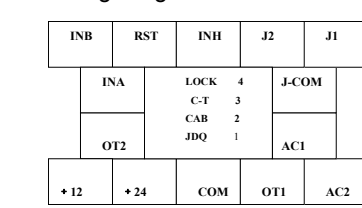

- INA A-phase input/Timing start
 - INB B-phase input
 - RST Reset input
 - INH Count disable input
 - J1, J2 Relay1, Relay2 output
 - J-COM Relay output COM
 - AC1, AC2 AC power supply
 - OT1, OT2 Transistor output1, 2
 - COM Common
 - +24 +24 power output/input
 - +12 +12 power output
- DIP Switches Set:
- JDQ Relay output set ("ON": Output enable)
 - CAB Input logic set ("ON": Positive logic)
 - C-T Timer/Counter set ("ON": Counter)
 - LOCK Reset locked ("ON": Locked cancel)

Input/Output circuit

Input circuit

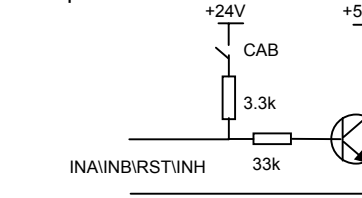

Output circuit

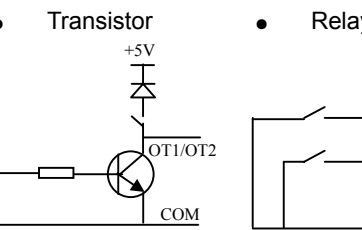

Important

- During relay output (JDQ is "ON"), transistor output too. The transistor output is tally with the TTL electric standard ("L" is above 0 to 2.4V, "H" is above 2.8 to 5V). Relay output would be disable when DIP JDQ is set to OFF. At this time, the transistor output high-voltage is up to Vcc (Vcc is external power, Vcc < 35V, I < 100mA, I is output current). We recommend you to set JDQ to OFF when you select pulse output, and when set to relay output, the output respond time (approx 10ms) should be considered.
- To ensure the counter resets naturally, please re-power ON after 2 seconds.
- The 0-V terminal and the common terminal are internally short-circuited.
- After changing setting, always press the ENT key to activate the new values.
- Empty terminals can not to be used as others.
- The +24V terminal is a output terminal when use AC input. It can be used as a power input terminal when use DC type products. There is no output on the +12V terminal in this way.

List of Max preset values for Timers

	4digits	6digits
S00.1	999.9s	SEC001 9999.90s ^{*4}
SEC1	9999s	SEC01 99999.9s
n0.01	9min59.9s	SEC1 999999s
nS0.1	99min59s	nS001 99min59.90s ^{*4}
n0.1	9999min	nS01 999min59.9s
HnS	9h59min5s ^{*3}	n01 9999min5s ^{*3}
Hn	99h59min	n1 99999min
HHHH	9999h	HnS 99h59min59s
		Hn 9999h59min

Note3: The last seconds is 10 seconds for the unit of time. The actual number of seconds to be multiplied by 10.

Note4: The last digit displays fixed at 0, the actual significant digit is only 5 digits. In addition, when set the timer, each digit corresponding to the maximum value on the form can be set. The value 0(*) expresses the digit is null.

Initializing the counter

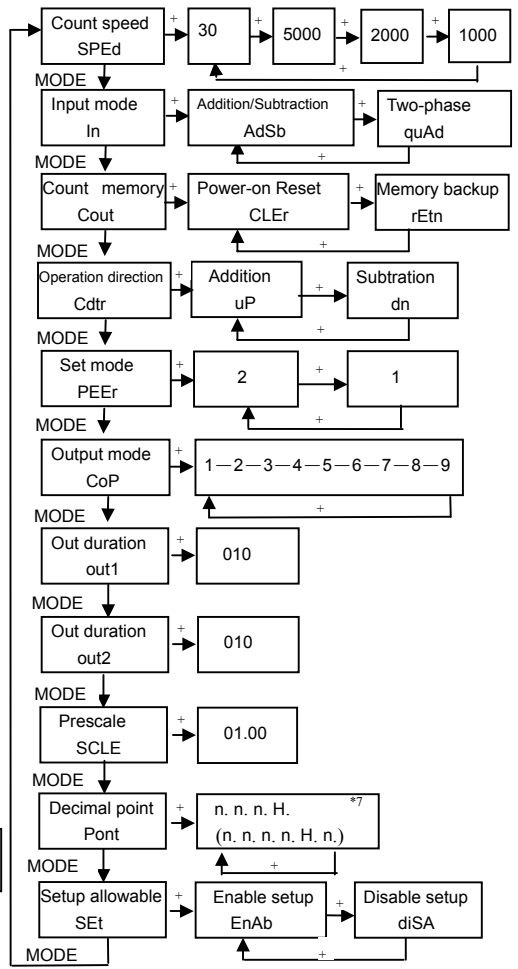

Note5: 4-digit counter displays S00.1, 6-digit counter displays SEC001

Note6: 4-digit counter displays n0.01, 6-digit counter displays nS001

Note7: 4-digit counter displays n.n.n.H, 6-digit counter displays n.n.n.n.H.n

List of error code

Mode	Content	Corrective Action	Status	description
Lamps off	Power is OFF	Turn the power on	not displayed	TMR/CNT/LOCK2 lamp should be display
confused indication	Power undulation (2 sec. within power ON)	Turn the power on	confused indication	TMR/CNT/LOCK2 lamp should be display
FFFFFF	Count has exceeded upper limit.	Reset the counter	None	Check the count range and correct the prescale
-FFFF	Count has decreased below lower limit.	Reset the counter	None	Check the count range and correct the prescale
E001	First setting overflow(upper limit)	Correct the setting	PS1 setting	
E002	First setting overflow(lower limit)	Correct the setting	PS1 setting	
E003	Second setting overflow(upper limit)	Correct the setting	PS2 setting	MODE key switched to PS2
E004	Second setting overflow(lower limit)	Correct the setting	PS2 setting	MODE key switched to PS2
E005	Counting speed memory data error	Correct the setting	Menu	
E006	Output mode memory data error	Correct the setting	Menu	
E007	OUT1 memory data error	Correct the setting	Menu	
E008	OUT2 memory data error	Correct the setting	Menu	
E009	Precale memory data error	Correct the setting	Menu	
E010	Decimal point memory data error	Correct the setting	Menu	
E011	Counting memory reset data error	Correct the setting	Menu	
E012	Input logic error	Correct the setting	Menu	
E013	Key protection memory data error	Correct the setting	Menu	
E014	Time output mode memory data error	Correct the setting	Menu	
E015	Time range memory data error	Correct the setting	Menu	
E016	Preset1 memory data error	Correct the setting	PS1 setting	MODE key switched to PS2
E017	Preset2 memory data error	Correct the setting	PS1 setting	MODE key switched to PS2

Note: The counter is enter edit status after press the ENT key when display the error codes.